

**065-73FXSM80MG Small Form-factor Pluggable (SFP)  
 Fast Ethernet / SONET OC-3 / SDH STM-1 Singlemode Fiber Interface Module**

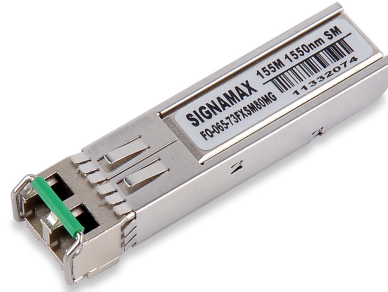

The Signamax 065-73FXSM80MG is a Small Form-factor Pluggable (SFP) multimode fiber module that supports Fast Ethernet, SONET OC-3, or SDH STM-1 over singlemode fiber cable at distances up to 80 kilometers. It adheres to the IEEE 802.3u standard for Fast Ethernet over singlemode fiber at 1550 nm, and is a cost-effective method of providing changeable Fast Ethernet / OC-3 / STM-1 singlemode interfaces to switches and media converters designed for these applications that are equipped with a standard 100Base SFP slot.

**Applications**

- Metro Access Rings
- Point-to-Point networking
- SONET OC-3 / SDH STM-1 over singlemode fiber
- 100BaseFX Fast Ethernet over singlemode fiber

**Key Features**

- Compliant with SFP MultiSource Agreement. Compliant with IEEE802.3u.
- RoHS Compliant.
- Duplex LC connector.
- 1550 nm uncooled DFP LD.
- 3.3V power supply.
- Hot-Pluggable capability.
- Extended EMI & ESD protection.
- Class 1 laser product complies with EN 60825-1 and EN 60950.
- Suitable for Fast Ethernet (100BaseFX), SONET OC-3, and SDH STM-1 applications.

**Ordering Information**

Part Number	Description
065-73FXSM80MG	100BaseFX / OC-3 / STM-1 SFP Module – SM/LC, 80 km

**Summary Specification**

PART NUMBER	Model / Spectrum	Light Source	Link Power Budget	Typical Max. Distance**	Supply Voltage	Operating Temp.
065-73FXSM80MG	LX 1550 nm	DFP Laser	29 dBm	80 km	3.3V	0 ~ 70 °C

\*\* Maximum distances attainable on singlemode fiber circuits are dependent upon a circuit's conditions; i.e., the number of splices and patch panels and the number of bends in the circuit path. For comparison with competing products, please use the Link Power Budget for meaningful comparisons.

[www.signamax.com](http://www.signamax.com)

16295 N.W. 13th Avenue • Miami, FL 33169 • 800.446.2377 • 305.944.7710 • Fax: 305.949.4483

Copyright 2011 Signamax, Inc./AESP, Inc. All rights reserved • Signamax Connectivity Systems is a trademark of AESP, Inc. • Specifications subject to change.

065-73FXSM80MG 09302011

SPECIFICATIONS

**DETAILED SPECIFICATIONS**

• **APPLICABLE STANDARDS**

IEEE 802.3u (100BaseFX Fast Ethernet)  
SONET OC-3  
Synchronous Digital Hierarchy (SDM) STM-1

• **ABSOLUTE MAXIMUM RATINGS**

**Storage Temperature:** TS -40 -- 85 °C  
**Supply Voltage:** V<sub>CC</sub> -0.5 -- 6.0 V  
**Input Voltage:** V<sub>IN</sub> -0.5 -- V<sub>CC</sub> V  
**Operating Humidity:** 0-85 %

• **RECOMMENDED OPERATING CONDITIONS**

PARAMETER	SYMBOL	MIN	MAX	UNITS	NOTE
Ambient Operating Temperature	T <sub>AMB</sub>	0	70	°C	
Supply Voltage	V <sub>CC</sub>	3.1	3.5	V	
Supply Current (3.3V)	I <sub>TX</sub> + I <sub>RX</sub>		85	mA	

• **TRANSMITTER ELECTRO-OPTICAL CHARACTERISTICS**

V<sub>CC</sub> = 3.1 V to 3.5V, T<sub>A</sub> = 0 °C to 70 °C

PARAMETER	SYMBOL	MIN	TYP.	MAX	UNITS	NOTE
Transmitter Differential Input Voltage	TD +/-	400		2000	mV p-p	BER < 10 <sup>-12</sup>
Output Optical Power 9/125 μm fiber	P <sub>out</sub>	-5		0	dBm	Average
Extinction Ratio	ER	8.2			dB	BER < 10 <sup>-12</sup>
Center Wavelength	λ <sub>c</sub>	1520	1550	1580	nm	BER < 10 <sup>-12</sup>
Spectral Width (20dB)	Δλ			<1	nm	BER < 10 <sup>-12</sup>
Side Mode Suppression Ratio	SMSR			30	dB	BER < 10 <sup>-12</sup>
Rise/Fall Time, (20–80%)	T <sub>r, f</sub>			3	ns	BER < 10 <sup>-12</sup>
Output Eye	Compliant with IEEE802.3u					
Transmit Fault Output-Low	TX_FAULT	V <sub>ee</sub>		V <sub>ee</sub> + 0.5	V	BER < 10 <sup>-12</sup>
Transmit Fault Output-High	TX_FAULT	2.0		V <sub>CC</sub>	V	BER < 10 <sup>-12</sup>
Transmit Disable-Low	TX_FAULT	V <sub>ee</sub>		V <sub>ee</sub> + 0.8	V	BER < 10 <sup>-12</sup>
Transmit Disable-High	TX_FAULT	2.0		V <sub>CC</sub>	V	BER < 10 <sup>-12</sup>

• **RECEIVER ELECTRO-OPTICAL CHARACTERISTICS**

V<sub>CC</sub> = 3.1 V to 3.5 V, T<sub>A</sub> = 0 °C to 70 °C

PARAMETER	SYMBOL	MIN	TYP.	MAX	UNITS	NOTE
Receiver Differential Output Voltage	RD +/-	600	800		mV p-p	
Optical Input Power-maximum	P <sub>IN</sub>	-3			dBm	A BER < 10 <sup>-12</sup>
Optical Input Power-minimum (Sensitivity)	P <sub>IN</sub>			-34	dBm	A BER < 10 <sup>-12</sup>
Operating Center Wavelength	λ <sub>c</sub>	1270		1620	nm	
Loss of signal –Asserted	P <sub>A</sub>	-45			dBm	A
Loss of signal –Deasserted	P <sub>D</sub>			-34.5	dBm	A
Receiver Loss of Signal Hysteresis		0.5	2		dB	A
<b>Note A: measured in the center of the eye opening with 2<sup>23</sup> -1 PRBS, NRZ</b>						

**DETAILED SPECIFICATIONS (continued)**

• **DIMENSIONS (mm)**

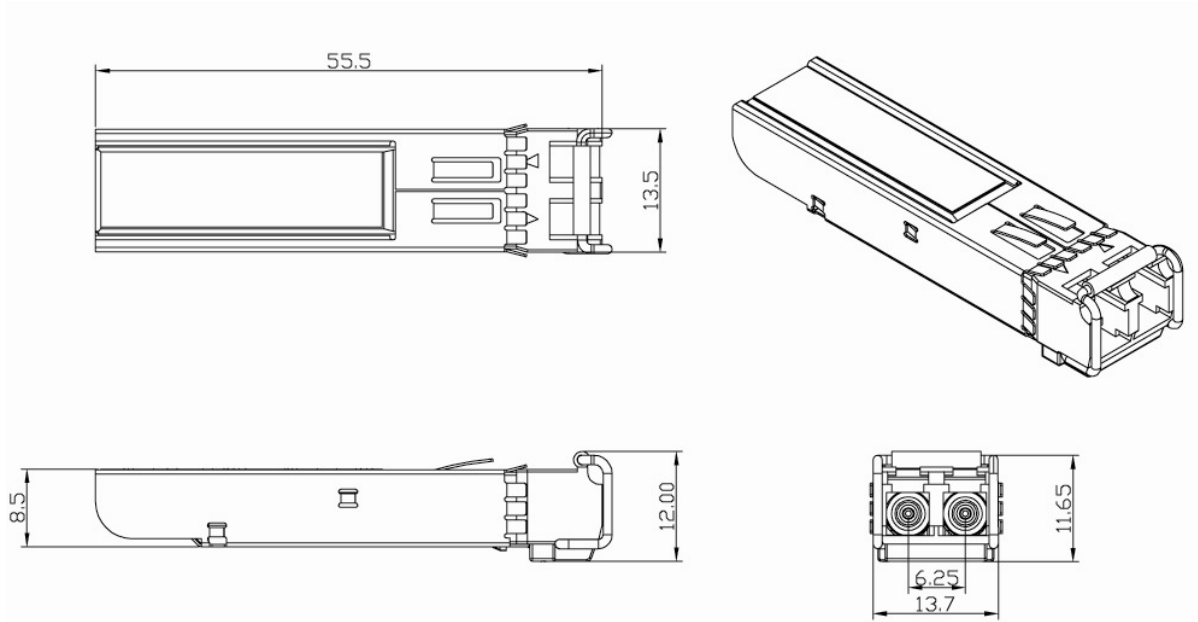

• **REGULATORY COMPLIANCE**

Feature	Test Method	Performance
Electrostatic Discharge (ESD) to optical connector	Variation of IEC 61000-4-2	Typically withstand at least 15kV without damage when port is contacted by Human Body Model probe.
Immunity	Variation of IEC 61000-4-3	Typically show no measurable effect from a 10 V/m field swept from 27 MHz to 1 GHz applied to the transceiver without a chassis enclosure.
Electromagnetic Interference (EMI)	FCC Class B CENELEC EN55022 Class B (CISPR 22A)	Margins are dependent on customer board and chassis design.
Laser Eye Safety	FDA21 CFR 1040.10 and 1040.11	Class 1 Laser Safety product.

• **WARRANTY**  
 Lifetime